

## User's Manual

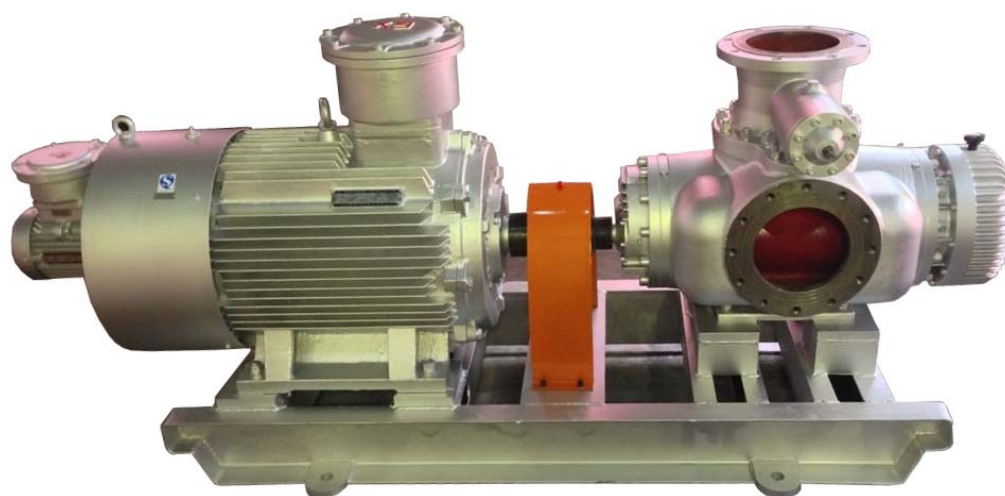

Office: 33 West 19th St, Suite 327, New York, NY 10011  
Factory: 15-17 Libella Court, Essex County, Newark, NJ 07105  
Tel: +1-646-619-1289 Fax: +1-212-400-7201

### **2G Series Twin Screw pump**



<b>I . MAIN FEATURES</b>	.....	1
<b>II . MEDIUM AND CHARACTERISTIC</b>	.....	1
<b>III. APPLICATION</b>	.....	1
<b>IV. MODE CODE</b>	.....	1
<b>V. THE STRUCTURE</b>	.....	3
<b>VI. CAPABILITY TABLE</b>	.....	4
<b>VII. INSTALL DIMENSION</b>	.....	6
<b>VIII . DIMENSION DRAWING</b>	.....	7
<b>IX. CURVE OF CAPABILITY</b>		
<b>X. BACK</b>		

**BACK**

● **MAIN FEATURE**

- \* 2G Twin Screw Pump is of high suction capacity, and self-priming;
- \* Continuous flow, without any pulsation;
- \* Running inside an oil-bath lubricated in the case of an exterior bearing. This arrangement allows non-lubricating fluid to be pumped;
- \* According to the high viscosity delivery medium heated designs with jacket at bottom of the pump.

● **MEDIUM AND CHARACTERISTIC RANGE**

- \* Handling with any clean liquid without solid;
- \* Viscosity: 1-1500mm<sup>2</sup>/s reducing rotating speed. Viscosity of medium can arrive 10<sup>5</sup>mm<sup>2</sup>/s;
- \* Pressure: ≤1.4MPa;
- \* Capacity: 10-350m<sup>3</sup>/h;
- \* Temperature: 80<sup>0</sup>C-150<sup>0</sup>C.

● **APPLICATION**

- \* Ship: Cargo & stripping pump. Ballast pump lubricating oil pump and fuel oil transfer pump.
- \* Power plant: Heavy & crude oil transfer pump. Heavy & crude oil burning pump.
- \* Chemical industry: Transfer for alkali, resins and paint etc.
- \* Oil refinery: Transfer and process pump for crude oil, fuel oil, bitumen and slop oil.
- \* Food industry: Transfer for emulsion, syrup, beer and wine etc.
- \* Oil field: Transfer for crude oil and slop oil.

● **MODE CODE OF TWIN SCREW PUMP OF SERIES 2G**

2GCSN150\*2-102-Z1M4W81

2G- Twin Screw Pump

C- Marine pump (no-signal general)

S- Double suction (no-signal single suction)

N- Short shaft (no-signal long shaft)

150- Diameter of screw-spindle (mm)

2- Standard number of pitch



102- Pitch (mm)

Z1- Special construction code (Table 3)

M4- Shaft sealing code (Table 1)

W81- Material code (Table 2)

※ TABLE 1 SHAFT SEALING CODE

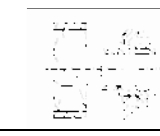
Code	Shaft seal	Remark	Code	Shaft seal	Remark
M0		Stuffing seal, temperature $\leq 80^{\circ}\text{C}$	M4		Mechanical seal temperature $\leq 80^{\circ}\text{C}$
M1		Stuffing seal lubrication by pumped medium, temperature $\leq 80^{\circ}\text{C}$	M5		Mechanical seal temperatue $\leq 150^{\circ}\text{C}$
M2		Stuffing seal lubricating and cooling by out medium, temperature $\leq 120^{\circ}\text{C}$			

※ TABLE 2

Material code	Casing material	Insert material	Screw material
W71	Cast iron	Cast iron	Alloy steel
W22	Nodular cast iron	Bronze	Alloy steel
W72	Cast iron	Nodular cast iron	Alloy steel
W21	Cast iron	Bronze	Alloy steel
W80	Nodular cast iron	Bronze	Chrome steel
W81	Nodular cast iron	Nodular cast iron	Chrome steel
W82	Bronze	Bronze	Chrome steel
W83	Cast iron	Bronze	Chrome steel
W90	Nodular cast iron	All bronze	Stainless steel
W91	All bronze	All bronze	Stainless steel
W92	Stainless steel	Stainless steel	Stainless steel

● THE STRUCTURE ILLUSTRATION OF 2G TWIN SCREW PUMP

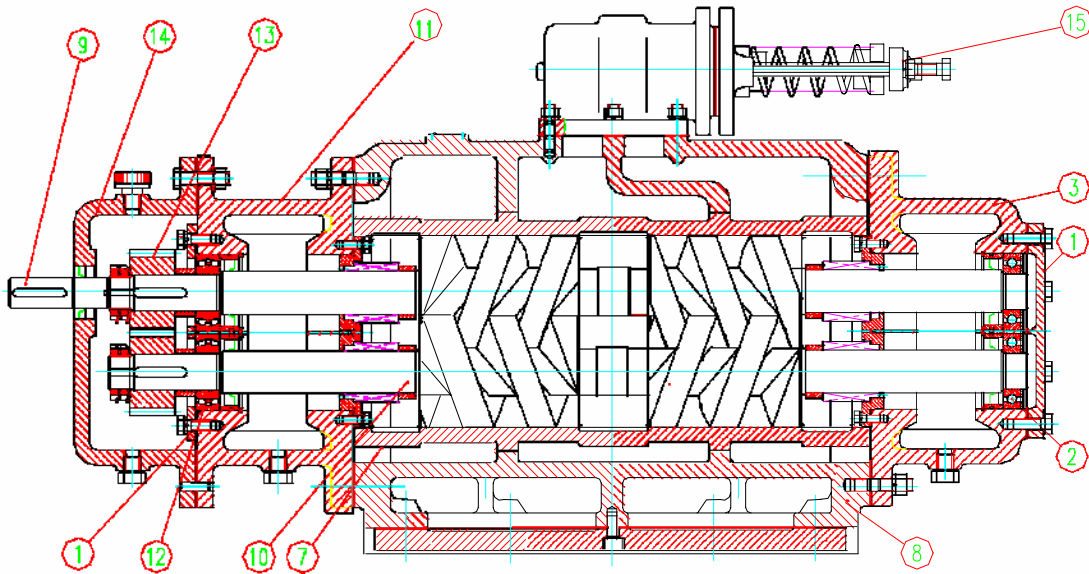

THE STRUCTURE OF TWIN SCREW PUMP

NO.	Name	NO.	Name
1	End cover	10	Driven screw-spindle
2	Bearing	11	Front support Bearing
3	Rear support	12	Time gear
7	Insert	13	Gear box
8	Casing	14	Safety-valve
9	Driving screw-spindle	15	

● **CAPABILITY TABLE**

Rotating speed n=1450r/min

Type	Pressure (MPa)	Viscosity=mm <sup>2</sup> /s													
		1		10		35		75		350		750		1500	
		M <sup>3</sup> /h	KW	M <sup>3</sup> /h	KW	M <sup>3</sup> /h	KW	M <sup>3</sup> /h	KW	M <sup>3</sup> /h	KW	M <sup>3</sup> /h	KW	M <sup>3</sup> /h	KW
88*2-60	0.2	31.1	3.0	33.4	3.2	34.6	3.8	35.1	4.4	35.9	6.2	31.6	7.6	36.1	9.3
	0.4	27.0	5.3	30.7	5.5	32.6	6.1	33.5	6.7	34.8	8.5	35.0	9.9	35.0	11.6
	0.6	23.9	7.6	28.6	7.8	31.1	8.4	32.3	9.0	33.9	10.8	34.2	12.2	34.2	13.8
	0.8	21.0	9.9	26.7	10.1	29.7	10.7	31.1	11.3	33.1	13.1	33.5	14.4	33.5	16.1
	1.0			25.0	12.4	28.5	13.0	30.1	13.6	32.4	15.3	32.8	16.7		
	1.2			23.5	14.7	27.4	15.3	29.2	15.8	31.8	17.6				
	1.4			22.0	17.0	26.3	17.6								
	NPSH	2.5m	2.5m	2.5m	2.5m	2.5m	3.0m	3.4m	3.8m						
105*2-64	0.2	52.4	4.7	55.1	5.0	56.6	5.9	57.2	6.7	58.2	9.4	58.4	11.4	58.4	13.9
	0.4	47.5	8.4	51.9	8.7	54.2	9.6	55.3	10.4	56.8	13.0	57.1	15.1	57.1	17.6
	0.6	43.8	12.1	49.5	12.4	52.5	13.3	53.8	14.1	55.8	16.7	56.1	18.7	56.1	21.2
	0.8	40.3	15.7	47.2	16.0	50.8	16.9	52.4	17.7	54.8	20.4	55.2	22.4	55.2	24.9
	1.0			45.2	19.7	49.3	20.6	51.2	21.4	54.0	24.0	54.4	26.1		
	1.2			43.3	23.3	48.0	24.2	50.1	25.1	53.2	27.7				
	1.4			41.5	27.0	46.7	27.9								
	NPSH	2.5m	2.6m	2.6m	2.6m	2.6m	3.3m	3.6m	4.0m						
118*2-78	0.2	83.8	7.3	87.1	7.8	88.8	9.2	98.6	10.4	90.8	14.4	91.0	17.6	91.0	21.4
	0.4	78.0	13.0	83.3	13.4	86.1	14.8	87.3	16.1	89.2	20.1	89.5	23.3	89.5	27.0
	0.6	73.6	18.6	80.3	19.1	83.9	20.5	85.5	21.7	87.9	25.7	88.3	28.9	88.3	32.7
	0.8	69.4	24.3	77.6	24.7	81.9	26.1	83.9	27.4	86.7	31.4	87.2	34.5	87.2	38.3
	1.0			75.2	30.4	80.2	31.8	82.4	33.0	85.7	37.1	86.3	40.2		
	1.2			73.0	36.1	78.6	37.4	81.1	38.7	84.8	42.7				
	1.4														
	NPSH	3.0m	3.0m	3.0m	3.2m	3.6m	4.1m	4.4m							
135*2-92	0.2	135.5	11.5	139.9	12.2	142.2	14.3	143.2	16.1	144.8	22.2	145.0	26.9	145.0	32.7
	0.4	127.8	20.5	134.8	21.2	138.5	23.2	140.2	25.1	142.6	31.2	143.0	35.9	143.0	41.7
	0.6	122.0	29.4	131.0	30.1	135.7	32.2	137.8	34.1	141.0	40.2	141.5	44.9	141.5	50.7
	0.8	116.5	38.4	127.3	39.1	133.1	41.2	135.6	43.1	139.4	49.2	140.1	53.9	140.1	59.6
	1.0			124.2	48.1	130.8	50.2	133.7	52.1	138.1	58.1	138.8	62.9		
	1.2			121.3	57.1	128.7	59.1	131.9	61.0	136.9	67.1				
	1.4			118.4	66.1										
	NPSH	3.3m	3.3m	3.3m	3.5m	4.2m	4.6m	5.3m							
150*2-112	0.2	186.5	15.7	192.1	16.7	195.0	19.5	196.3	22.1	198.2	30.5	198.6	37.0	198.6	44.9
	0.4	176.8	28.0	185.6	28.9	190.3	31.8	192.4	34.4	195.0	42.8	196.0	49.3	196.0	57.2
	0.6	160.3	40.3	180.7	41.2	186.7	44.1	189.4	46.7	193.4	55.1	194.1	61.6	194.1	69.5
	0.8	162.4	52.5	176.1	53.5	183.4	56.3	186.6	58.9	191.5	67.3	192.3	73.8	192.3	81.7
	1.0	156.3	64.8	172.1	65.8	180.5	68.6	184.2	71.2	198.8	79.6	190.7	86.1		
	1.2			168.5	78.0	177.8	80.0	182.0	83.5	188.2	91.0				
	1.4			164.8	90.3										
	NPSH	3.7m	3.7m	3.7m	4.0m	4.6m	5.3m	5.8m							
165*2-112	0.2	249	20.8	255	22.1	259	25.9	261	29.3	263	40.4	264	49.0	264	59.5
	0.4	236	37.1	247	38.4	253	42.2	256	45.6	260	56.7	261	65.3	261	75.7
	0.6	227	53.4	241	54.7	249	58.5	252	61.9	257	73.0	258	81.6	258	92.0
	0.8	218	69.7	235	71.0	245	74.7	249	78.2	255	89.3	256	97.9	256	108.3
	1.0	211	86.0	230	87.3	241	91.0	246	94.5	253	105.6	254	114.2	254	124.8
	1.2			226	103.5	238	107.3	243	110.7	251	121.8	252	130.4		
	1.4			221	119.8	234	123.6	240	127.0						
	NPSH	4.0m	4.0m	4.0m	4.2m	5.1m	5.8m	6.5m							
182*2-122	0.2	333	27.0	331	28.7	336	33.6	338	38.0	341	52.5	342	63.7	342	77.3
	0.4	307	48.1	321	49.8	329	54.7	332	59.1	337	73.6	338	84.8	338	98.4
	0.6	296	69.2	313	70.8	323	75.8	327	80.2	334	94.7	335	105.9	335	120.0
	0.8	285	90.3	306	91.9	318	96.8	323	101.3	331	116.0	332	127.0	332	141.0
	1.0	275	111.4	300	113.0	313	117.9	319	122.4	328	136.8	329	148.0		
	1.2			294	134.0	309	139.0	316	143.5	325	157.9				
	1.4			289	155.2	305	160.1								
	NPSH	4.2m	4.2m	4.2m	4.5m	5.5m	6.2m	7.2m							

Valid for fluid without entrained air (gas).

Rotating speed n=970r/min

Type	Pressure (MPa)	Viscosity=mm <sup>2</sup> /s													
		1		10		35		75		350		750		1500	
		M <sup>3</sup> /h	KW	M <sup>3</sup> /h	KW	M <sup>3</sup> /h	KW	M <sup>3</sup> /h	KW	M <sup>3</sup> /h	KW	M <sup>3</sup> /h	KW	M <sup>3</sup> /h	KW
88*2-60	0.2	18.5	1.9	20.8	2.0	22.1	2.3	22.6	2.6	23.4	3.6	23.6	4.3	23.6	5.2
	0.4			18.1	3.6	20.1	3.9	21.0	4.2	22.3	5.1	22.5	5.8	22.5	6.7
	0.6			16.1	5.1	18.6	5.4	19.7	5.7	21.4	6.0	21.7	7.4	21.7	8.3
	0.8					17.2	6.9	18.6	7.2	20.6	8.2	20.9	8.0	20.9	9.8
	1.0					16.0	8.5	17.6	8.8	19.9	9.7	20.3	10.1	20.3	11.3
	1.2					14.9	10.0	16.6	10.3	19.2	11.2				
	1.4					13.8	11.5	15.7	11.8						
	NPSH	2m	2m	2m	2m	2m	2.3m	2.7m	3m						
105*2-64	0.2	32.3	2.7	35.1	3.2	36.6	3.6	37.2	4.1	38.2	5.5	38.4	6.5	38.4	7.8
	0.4	27.5	5.5	31.9	5.6	34.2	6.1	35.3	6.5	36.8	7.9	37.1	9.0	37.1	10.3
	0.6			29.4	8.1	32.4	8.5	33.8	9.0	35.8	10.4	36.1	11.4	36.1	12.7
	0.8			27.1	10.5	30.8	11.0	32.4	11.4	34.8	12.8	35.2	13.9	35.2	15.2
	1.0			25.1	13.0	29.3	13.4	31.2	13.9	34.0	15.3	34.4	16.3	34.4	17.6
	1.2			23.3	16.4	28.0	15.9	30.1	16.3	33.2	17.7	33.7	18.8		
	NPSH	2.1m	2.1m	2.1m	2.1m	2.1m	2.5m	3.0m	3.2m						
	118*2-78	0.2	52.9	4.7	56.1	4.9	57.9	5.6	58.7	6.3	59.8	8.4	60.0	15.5	60.0
0.4		47.0	8.4	52.3	8.7	55.1	9.4	56.3	10.1	58.2	12.2	58.6	13.8	58.5	15.8
0.6				49.4	12.5	53.0	13.2	54.6	13.8	57.0	16.0	57.4	17.6	57.4	19.6
0.8				46.7	16.5	51.0	17.0	52.9	17.6	55.8	19.8	56.3	21.4	56.3	23.4
1.0				44.3	20.0	49.3	20.8	51.5	21.4	54.8	23.5	55.3	25.2	55.3	27.2
1.2				42.1	23.8	47.7	24.5	50.1	25.2	53.9	27.3				
NPSH		2.2m	2.2m	2.2m	2.2m	2.2m	2.7m	3.2m	3.4m						
135*2-92		0.2	86.4	7.3	90.8	7.7	93.1	8.8	94.1	9.8	95.7	13.0	95.9	15.5	95.9
	0.4	78.7	13.3	85.7	13.7	89.4	14.8	91.0	15.8	93.5	19.0	93.9	21.5	93.9	25.4
	0.6	72.9	19.3	81.8	19.7	86.6	20.8	88.7	21.8	91.9	25.0	92.4	27.5	92.4	30.5
	0.8			78.2	25.7	83.9	26.8	86.5	27.8	90.3	31.0	91.0	33.5	91.0	36.5
	1.0			75.1	31.7	81.7	32.8	84.6	33.8	89.0	37.0	89.7	39.5	89.7	42.5
	1.2			72.1	37.7	79.5	38.8	82.8	39.8	87.8	43.0				
	1.4			62.9	43.7	77.4	44.8								
	NPSH	2.5m	2.5m	2.5m	2.5m	2.5m	3.0m	3.5m	4.0m						
150*2-102	0.2	119.4	10.0	124.9	10.5	127.9	12.0	129.2	13.4	131.1	17.8	131.4	21.2	131.4	25.4
	0.4	109.6	18.2	118.5	18.7	123.2	20.2	125.3	21.6	128.4	26.0	128.9	29.4	128.9	33.6
	0.6	102.2	26.4	113.6	26.9	119.6	28.4	122.3	29.8	126.3	34.2	127.0	37.6	127.0	41.8
	0.8			109.1	35.2	116.3	36.7	119.5	38.0	124.3	42.4	125.2	45.8	125.2	50.0
	1.0			105.1	43.4	113.4	44.9	117.1	46.2	122.7	50.6	123.6	54.1	123.6	58.2
	1.2			101.3	51.6	110.7	53.1	114.8	54.4	121.1	58.8	122.1	62.3		
	1.4			97.6	59.8	108.0	61.3								
	NPSH	2.7m	2.7m	2.7m	2.7m	2.7m	3.2m	3.7m	4.2m						
165*2-112	0.2	159	13.3	167	14.0	170	15.9	172	17.7	174	23.6	175	28.1	175	33.6
	0.4	147	24.2	158	24.9	164	26.8	167	28.6	171	34.5	172	39.0	172	44.5
	0.6	138	35.1	152	35.7	160	37.7	163	39.5	168	45.4	169	49.9	169	55.4
	0.8			146	46.6	156	48.6	159	50.4	166	56.3	167	60.8	167	66.3
	1.0			141	57.5	152	59.9	157	61.3	164	67.2	165	71.7	165	77.21
	1.2			137	68.4	149	70.1	154	72.2	162	78.1	163	82.6	163	88.1
	1.4			132	79.3	145	81.1	151	83.1	160	88.9				
	NPSH	3.0m	3.0m	3.0m	3.0m	3.0m	3.5m	4.0m	4.5m						
182*2-122	0.2	208	17.2	216	18.0	221	20.7	223	23.0	226	30.6	226	36.5	226	43.7
	0.4	192	31.3	206	32.2	213	34.8	217	37.1	222	44.7	222	50.6	222	57.8
	0.6	180	45.4	198	46.3	208	48.9	212	51.2	218	58.8	219	64.7	219	71.9
	0.8			191	60.4	203	63.0	208	65.3	215	72.9	217	78.8	217	86.0
	1.0			185	74.5	198	77	204	79.4	213	87.0	214	92.9	214	100.1
	1.2			179	88.6	194	91.2	200	93.6	210	101.0	212	107.0		
	1.4			173	102.7	190	105.3								
	NPSH	3.2m	3.2m	3.2m	3.2m	3.2m	3.7m	4.2m	4.8m						

Valid for fluid without entrained air (gas). Accuracy according to GB9064-88



●INSTALLING DIMENSIONS

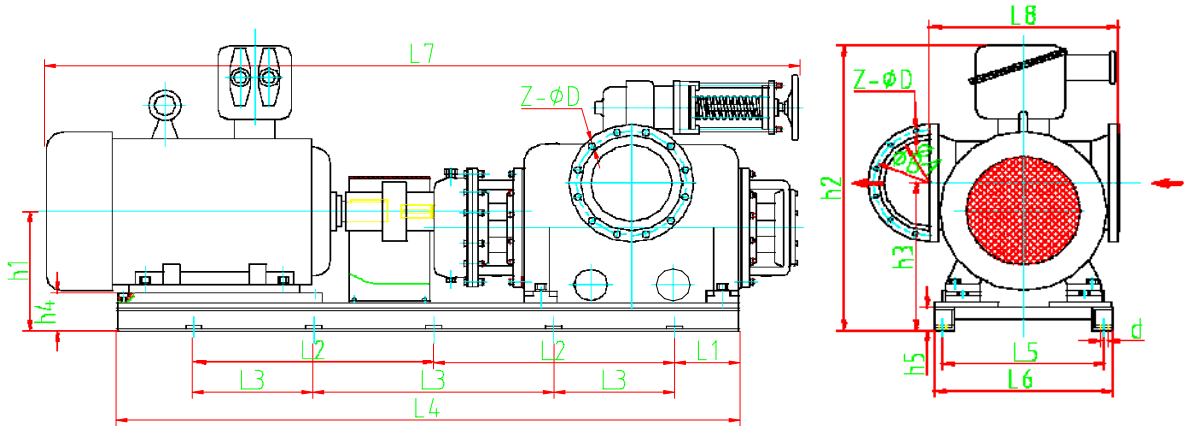

Code	Motor	Installing dimension														ΦA*ΦB*ΦC*Z
		L1	L2	L3	L4	L5	L6	L7	L8	h1	h2	h3	h4	h5	d	
2GCS 88*2	Y132S	110	510		1250	500	560	1426	460	340	598	415	100	35	25	Φ100*Φ180*Φ18*8
	Y132M	110	510		1250	500	560	1426	460	340	598	415	100	35	25	
	Y160M	110	590		1400	500	560	1557	460	340	598	415	100	35	25	
	Y160L	110	590		1400	500	560	1602	460	340	598	415	100	35	25	
	Y180M	110	590		1400	500	560	1627	460	340	598	415	100	35	25	
	Y180L	110	590		1400	500	560	1667	460	340	598	415	100	35	25	
2CGS 105*2	Y160L	250	500		1500	520	600	1652	480	355	616	420	100	50	25	Φ125*Φ210*Φ18*8
	Y180L	250	500		1500	520	600	1690	480	355	616	420	100	50	25	
	Y200L	261	522		1565	590	670	1755	480	355	616	420	100	50	25	
	Y225L	261	522		1565	590	670	1800	480	355	616	420	100	50	25	
2CGS 118*2	Y160L	120	665		1570	500	560	1830	500	370	720	445	100	35	25	Φ150*Φ240*Φ23*8
	Y180L	120	665		1570	500	560	1895	500	370	720	445	100	35	25	
	Y200L	120	710		1660	560	620	1965	500	370	720	445	100	35	25	
	Y225S	120	710		1660	560	620	2015	500	370	720	445	100	35	25	
	Y225M	120	710		1660	560	620	2040	500	370	720	445	100	35	25	
2CGS 135*2	Y180L	296	592		1775	620	700	1950	550	390	765	465	100	50	25	Φ200*Φ295*Φ22*12
	Y200L	296	592		1775	620	700	2015	550	390	765	465	100	50	25	
	Y225M	296	592		1775	620	700	2085	550	390	765	465	100	50	25	
	Y250M	324	653		1955	720	800	2170	550	390	765	465	100	50	25	
	Y280S	324	653		1955	720	800	2250	550	390	765	465	100	50	25	
2CGS 150*2	Y280M	324	653		1955	720	800	2300	550	390	765	465	100	50	25	Φ250*Φ355*Φ26*12
	Y200L	300	625		1850	680	760	2180	600	415	915	510	100	50	25	
	Y225M	300	625		1850	680	760	2250	600	415	915	510	100	50	25	
	Y250M	320	670		1985	680	760	2335	600	415	915	510	100	50	25	
	Y280S	320	670		1985	680	760	2412	600	415	915	510	100	50	25	
	Y280M	305	755		2146	805	885	2462	600	415	915	510	100	50	25	
2CGS 165*2	Y315S	305	755		2146	805	885	2632	600	425	915	510	100	50	25	Φ250*Φ355*Φ27*12
	Y225S	250		510	2020	550	610	2256	640	555	1052	645	220	22	27	
	Y225M	250		510	2020	550	610	2281	640	555	1052	645	220	22	27	
	Y250M	250		510	2020	550	610	2361	640	555	1052	645	220	22	27	
	Y280S	280		590	2290	600	660	2443	640	555	1052	645	220	22	27	
	Y280M	280		590	2290	600	660	2493	640	555	1052	645	220	22	27	
	Y280M	280		590	2290	600	660	2643	640	555	1052	645	220	22	27	
Y315S	280		590	2290	600	660	2693	640	555	1052	645	220	22	27		
2CGS 182*2	Y225M	245		510	2020	550	610	2346	700	575	1117	685	220	22	28	Φ300*Φ410*Φ26*12
	Y280S	260		590	2290	600	660	2508	700	575	1117	685	220	22	28	
	Y280M	260		590	2290	600	660	2558	700	575	1117	685	220	22	28	
	Y315S	260		590	2290	600	660	2734	700	575	1117	685	220	22	28	
	Y315M	260		590	2290	600	660	2784	700	575	1117	685	220	22	28	
335M	40		750	2330	720	780	2810	700	575	1117	685	220	22	28		

● DIMENSION DRAWING

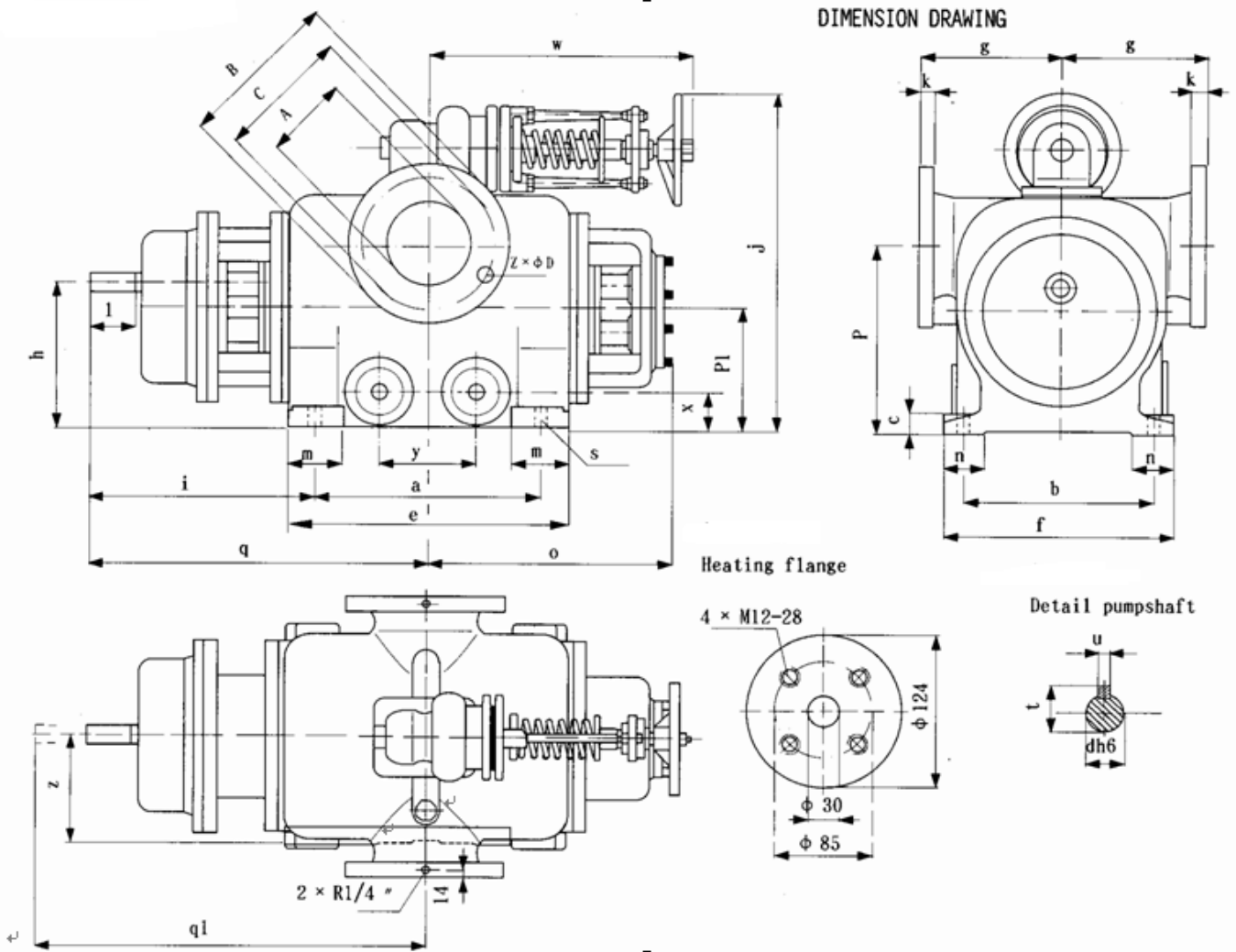

Type	A	B	C	Z*ϕD	a	b	c	e	f	g	h	i	j	k	m	n	S
88	100	215	180	8*ϕ18	325	310	35	415	350	230	230	362.5	488	26	90	60	4*18
105	125	254	210	8*ϕ18	370	330	35	460	370	240	245	381	506	26	90	60	4*18
118	150	295	240	8*ϕ22	400	335	35	500	380	250	260	400	610	26	100	62	4*22
135	200	340	295	12*ϕ22	480	400	40	570	450	275	280	406	655	30	100	70	4*22
150	250	405	355	12*ϕ26	580	450	40	690	500	300	305	459	805	32	100	90	4*23
165	250	405	355	12*ϕ26	620	490	45	740	550	320	335	500	832	32	120	90	4*27
182	300	460	410	12*ϕ26	670	540	45	790	600	350	355	515	897	34	120	90	4*27
Type	o	p	p1	q	q1	w	x	y	z	d	l	t	u	Safe valve	Weight		
88	395	305	197.5	525	1150	275	70	126	162.5	28	60	31	8		46	VO	165
105	413	310	207	566	1200	275	70	150	169	28	60	31	8		46	VO	220
118	429	335	218	600	1300	467	70	170	185	32	80	35	10		70	VOE	275
135	465	355	233	645	1400	467	70	200	206	38	80	41	10		70	VOE	380
150	525	400	252.5	745	1600	565	70	250	225	42	110	45	12		100	VOE	535
165	581	425	277	810	1760	565	70	300	245	45	110	48.5	14		100	VOE	760
182	610	465	292	850	1360	565	70	300	267	50	110	53.5	14		100	VOE	995

**TABLE 3 SPECIAL CONSTRUCTION CODE**

Code	Construction feature	Remark column
Z0	<ol style="list-style-type: none"><li>1. Casing separated from cylinder liner</li><li>2. Casing, cylinder liner, bearing support are casts</li></ol>	The code can be omitted in the pump code
Z1	<ol style="list-style-type: none"><li>1. The same as Z0</li><li>2. The same as Z0</li><li>3. A heating liner under the casing</li></ol>	

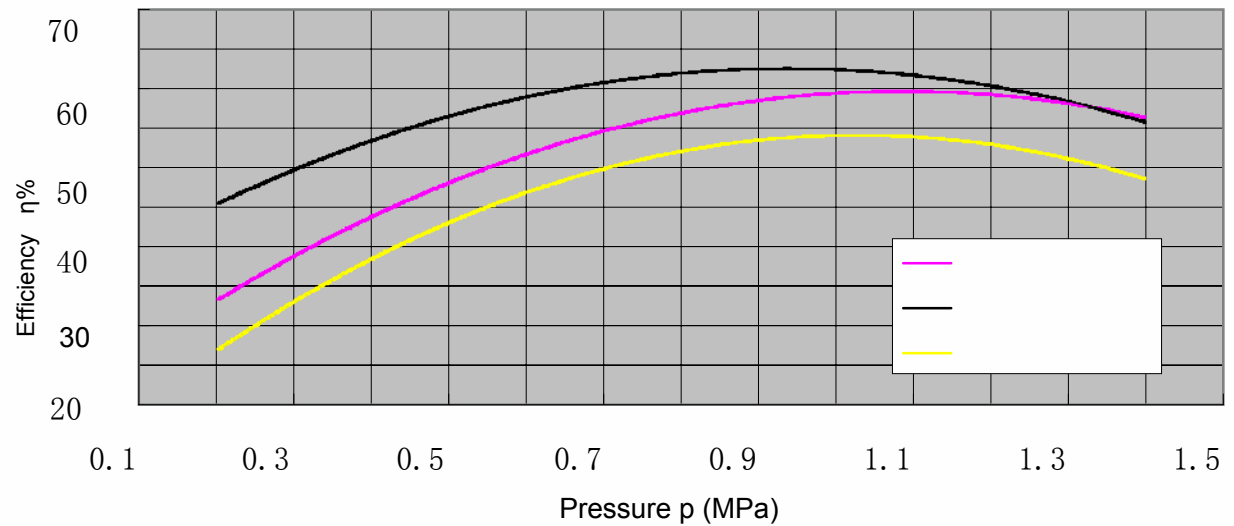
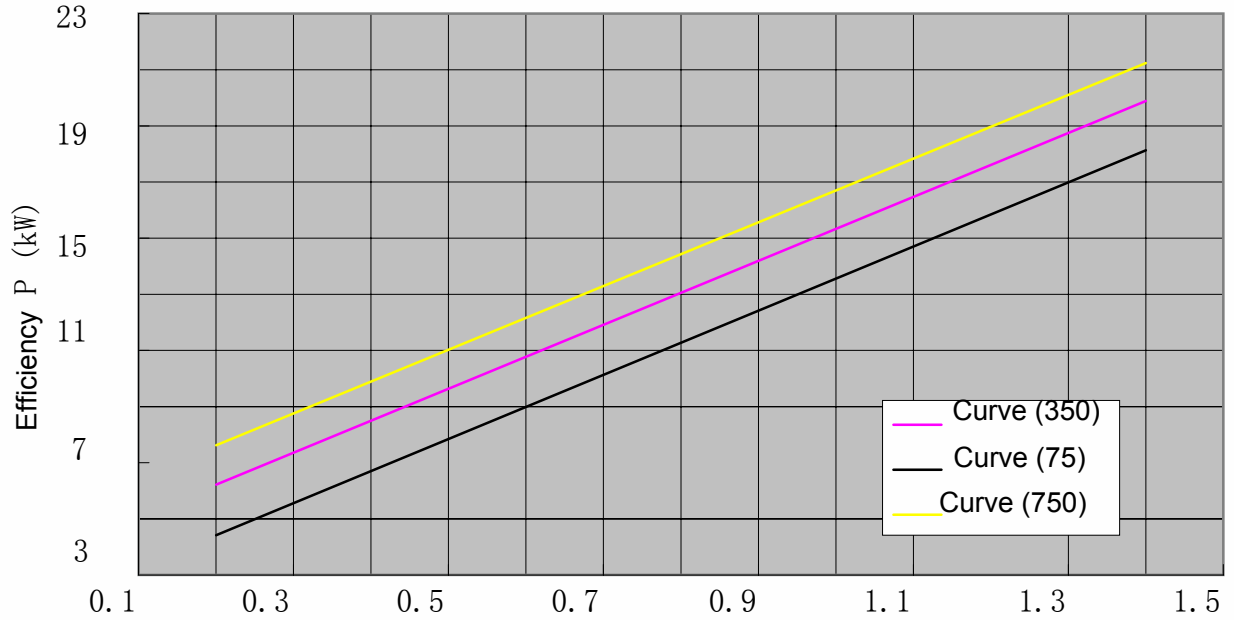
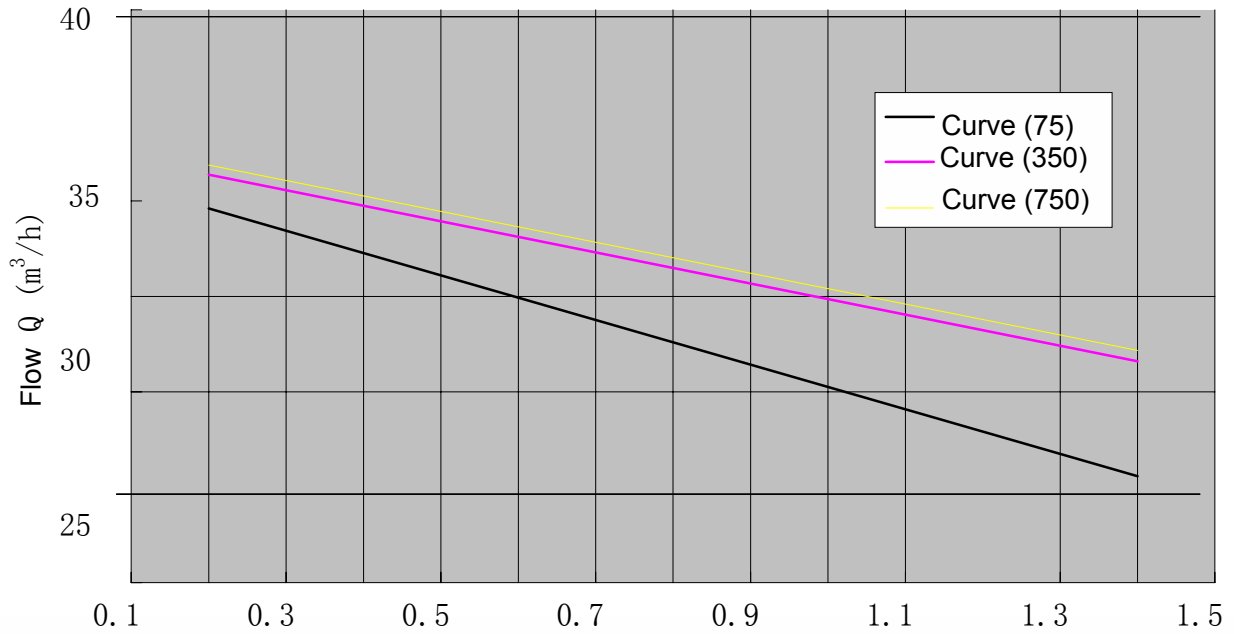

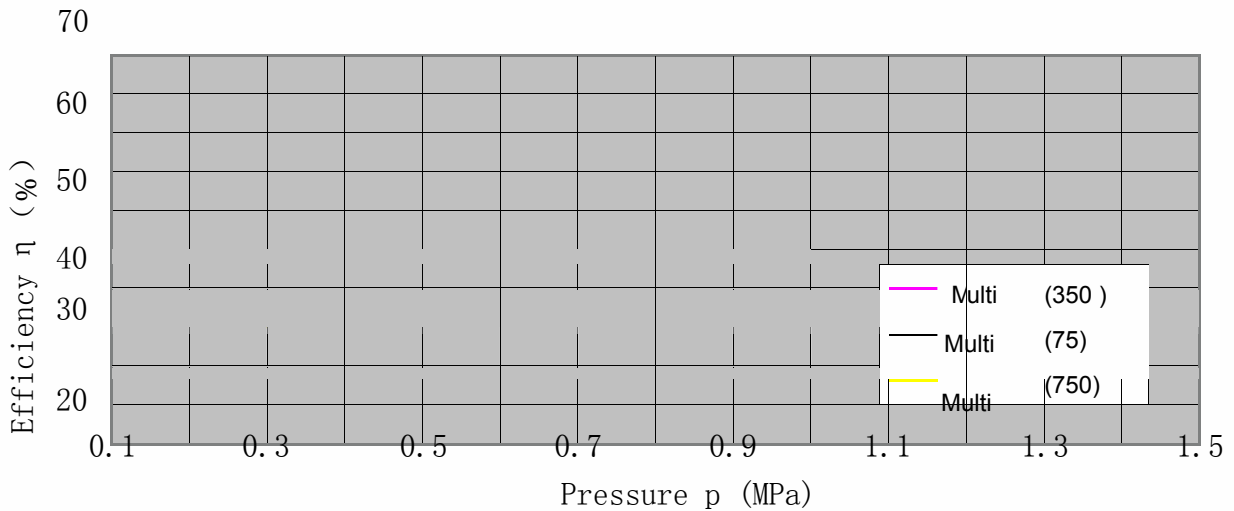
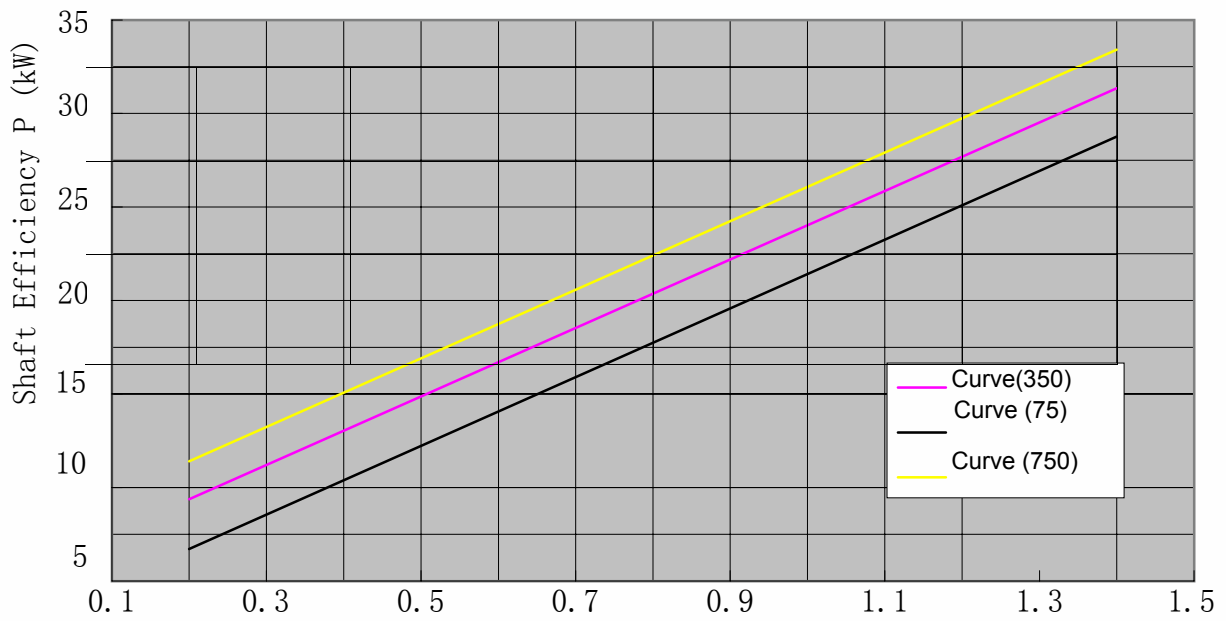
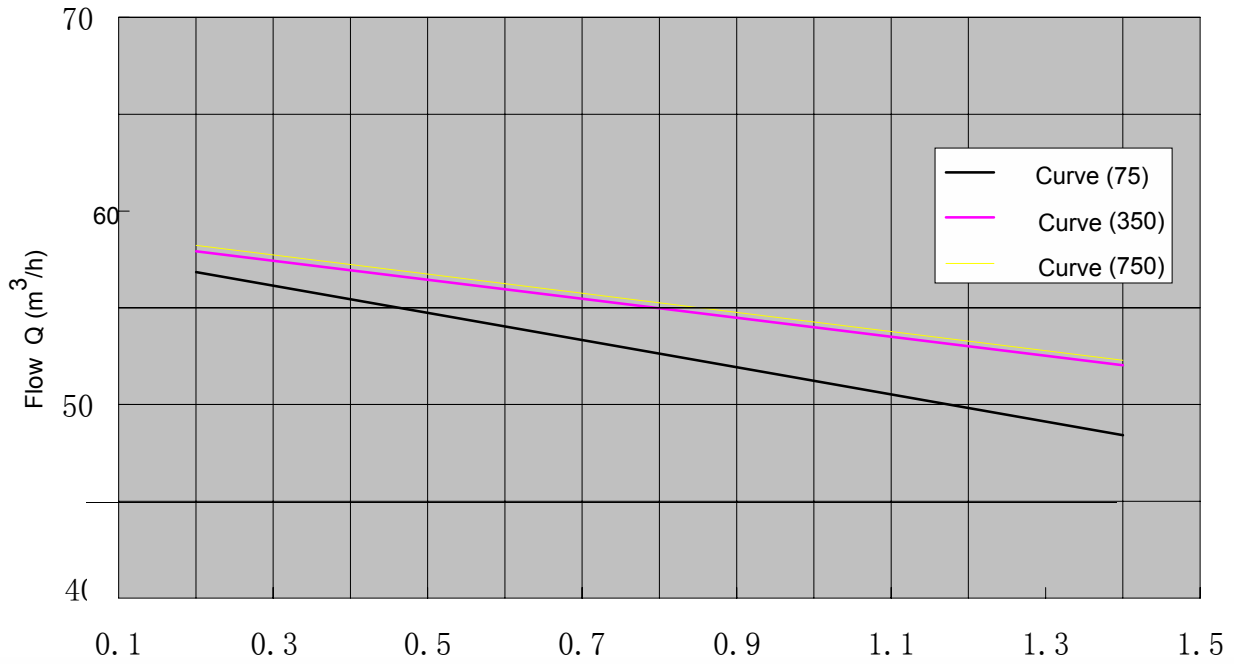

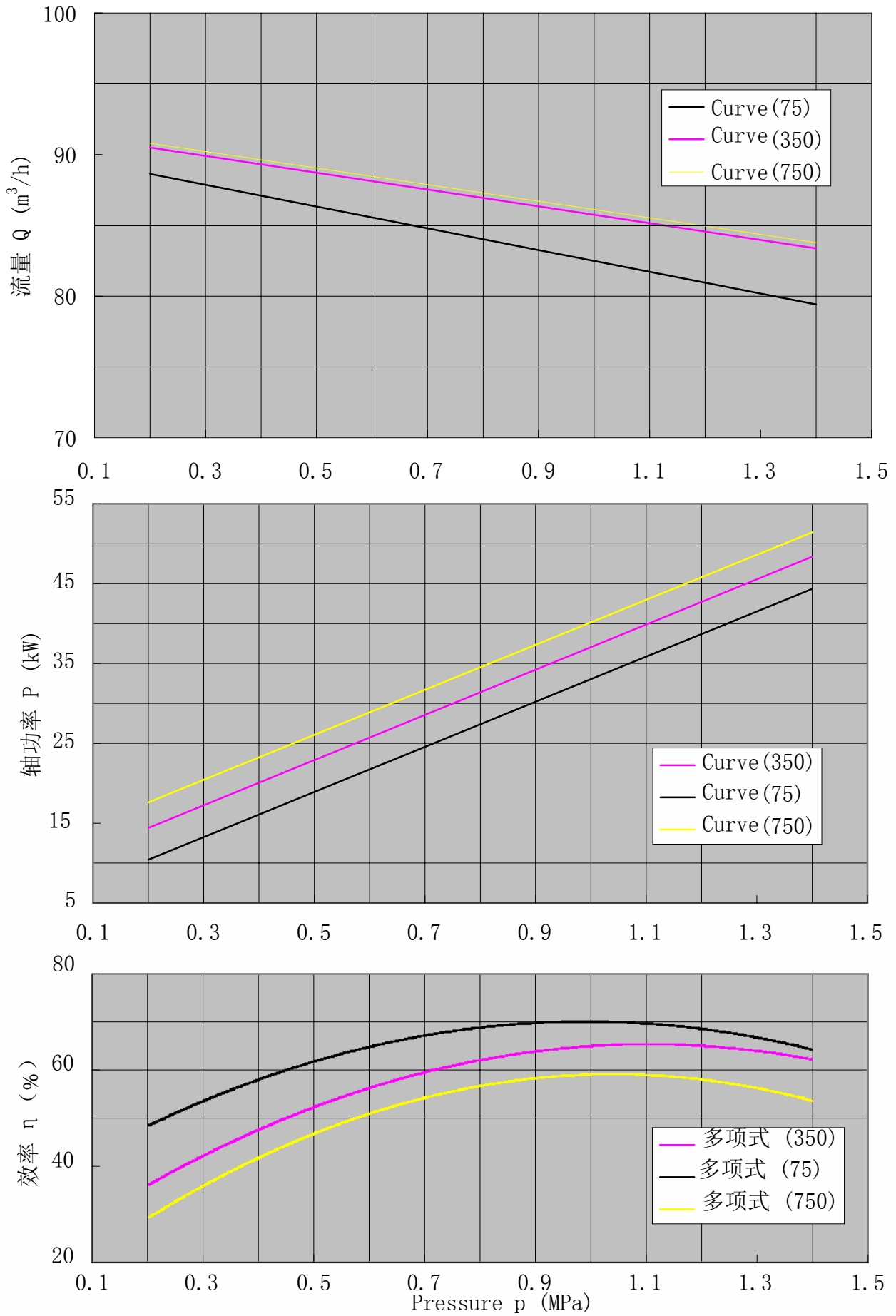

2G135×2-92 Performance Curve Speed:970r/min Viscosity:75、350、750mm<sup>2</sup>/s

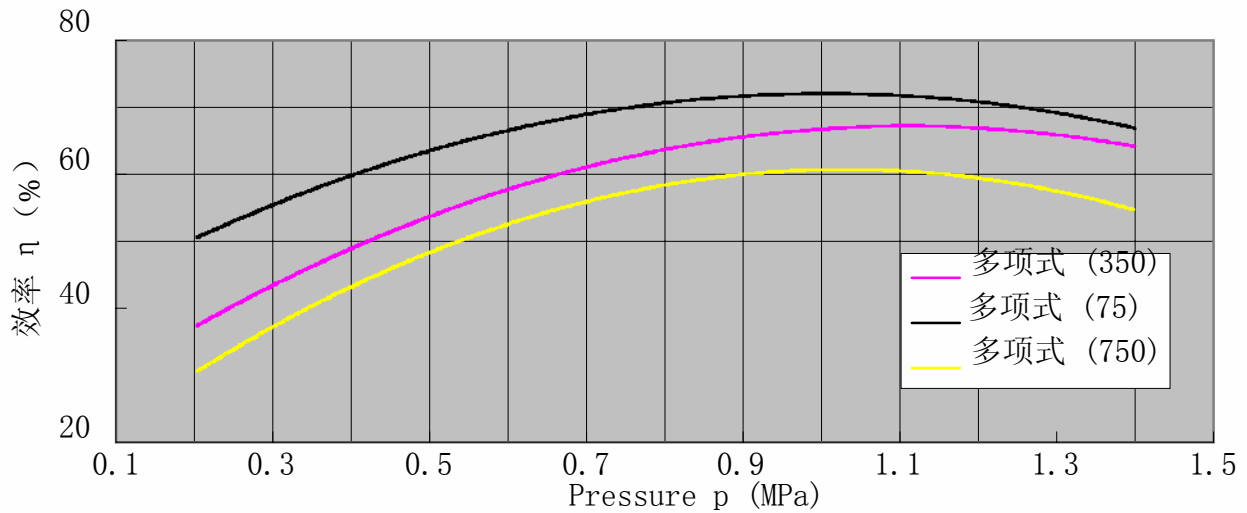
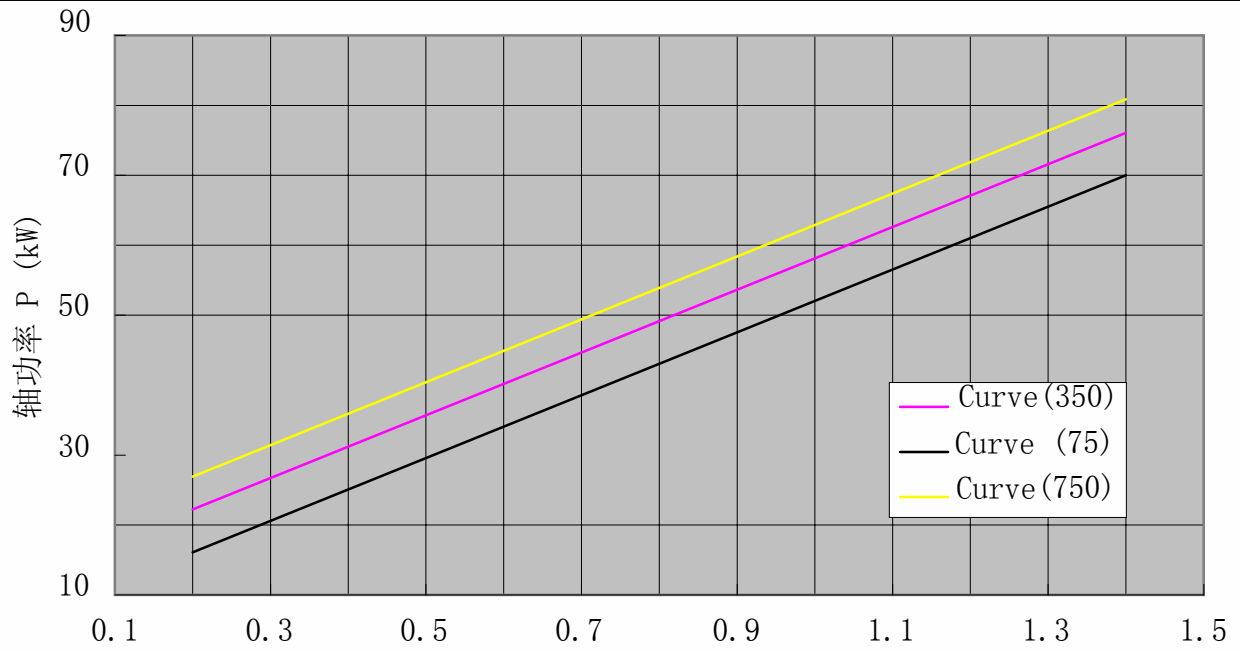
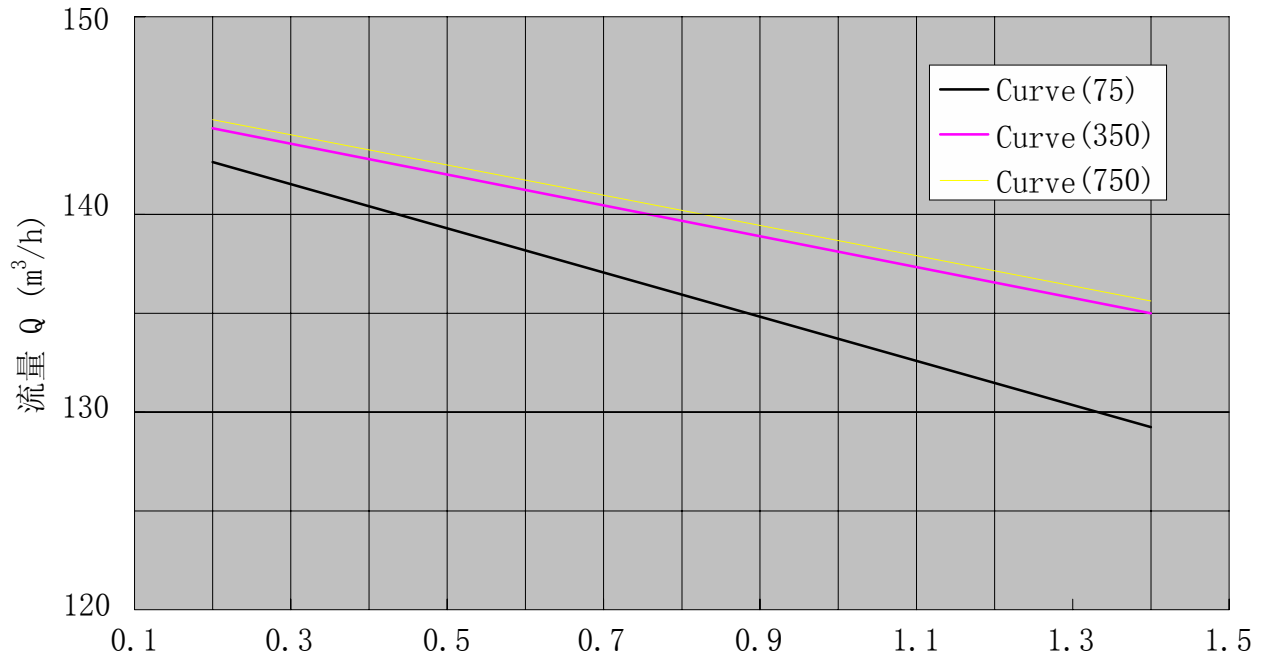

2G150×2-102 Performance Curve Speed Viscosity:75、350、750mm<sup>2</sup>/s

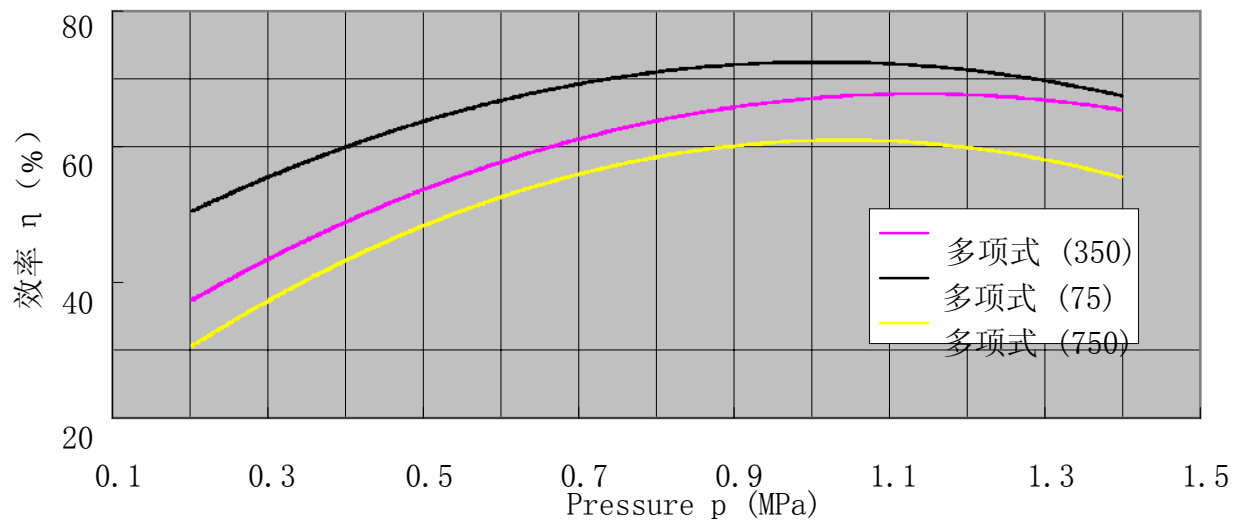
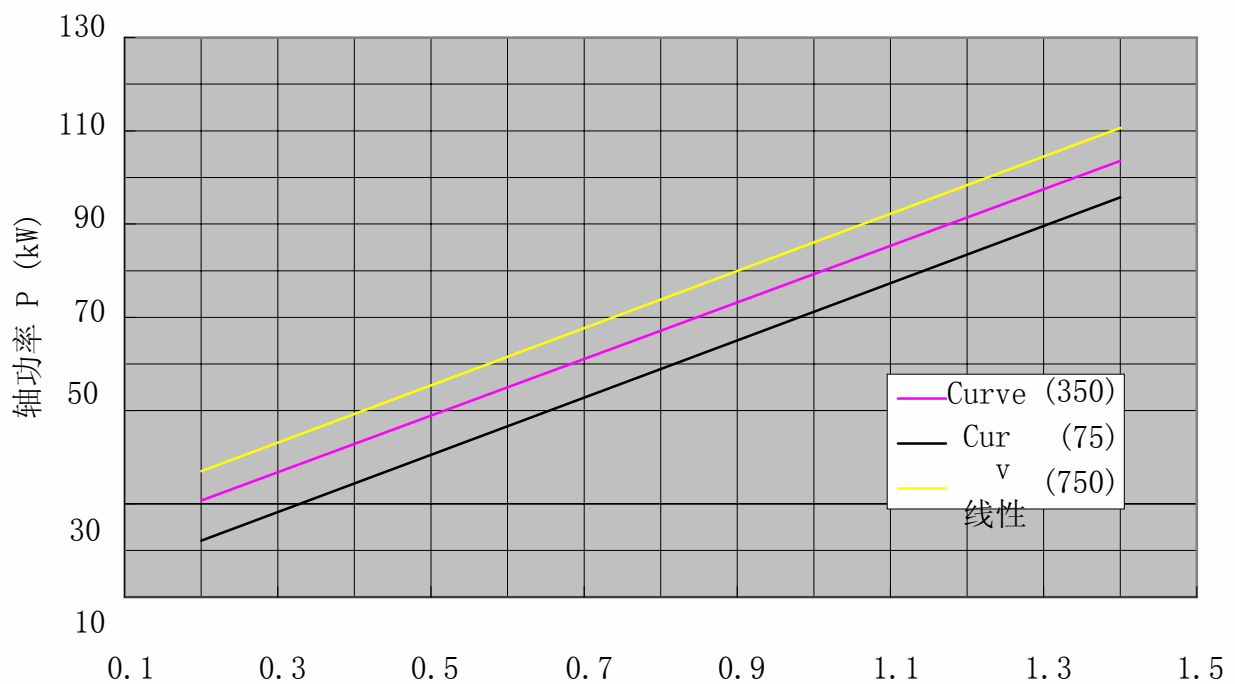
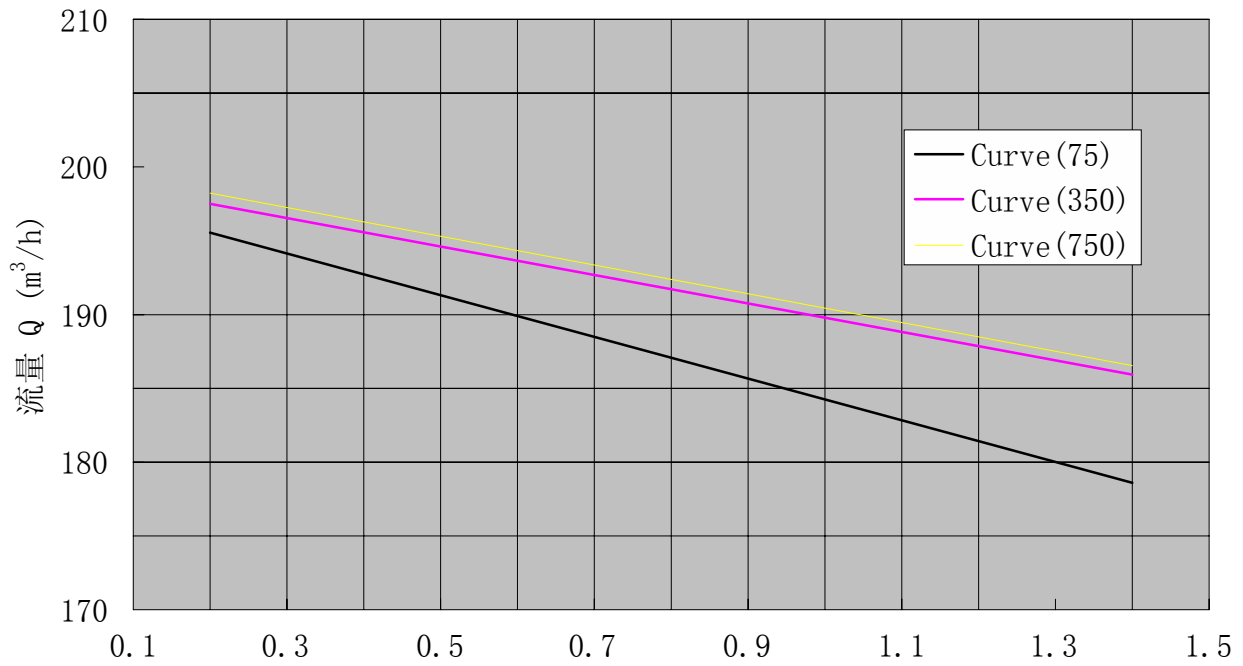



2G165×2-112 Performance Curve Speed:1450r/min Viscosity:75、350、750mm<sup>2</sup>/s

